

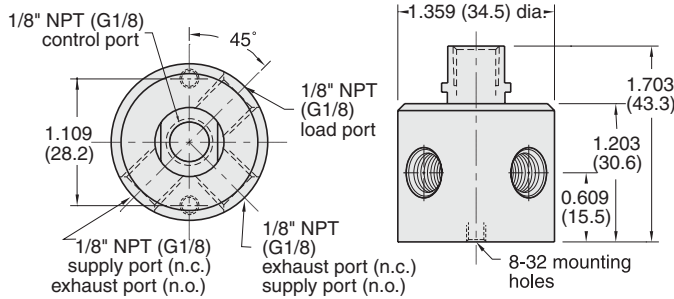

# SPECIAL PILOTED 3-WAY VALVES

## 3-Way N.O. or N.C. Air-Piloted Valves



Top View

Side View

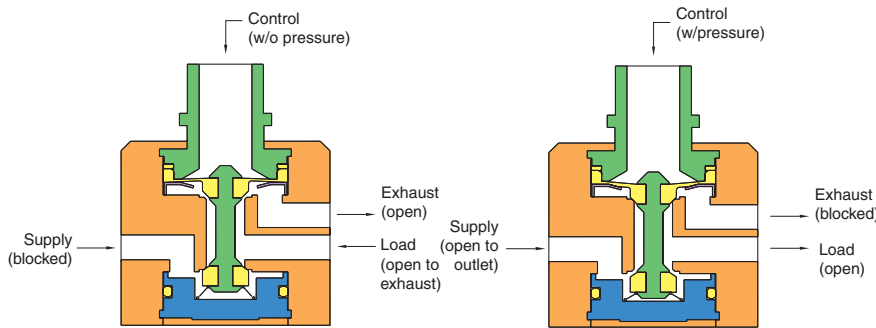

Valve Closed

Valve Open

**Medium:** Air

**Material:** Anodized aluminum body, Buna-N diaphragms

**Input Pressure:** 1 to 100 psig/7 bar max.

**Air Flow:** 22 scfm @ 100 psig; 530 l/min @ 6 bar

**Bleed:** 0.1 scfm @ 100 psig

**Minimum Pilot Pressure:**

N.O. - 90% of supply pressure  
N.C. - 60% of supply pressure

**Response Time:** 15 milliseconds after pilot pressure reaches switch point

**Operating Speed:** 1,100 CPM

Part No.	Description
<b>2012</b>	Piloted Valve, 1/8" NPT
<b>2012-MG</b>	Piloted Valve, G1/8
<b>2012-VAC</b>	Valve for Vacuum Operation (requires positive pressure pilot signal)
<b>2012-G</b>	Valve for Liquid Adhesives (silicone diaphragm and seals), 1/8" NPT
<b>2012-G-MG</b>	Valve for Liquid Adhesives (silicone diaphragm and seals), G1/8

## 3-Way N.O. or N.C. Electronically Piloted Valves



3-Way Normally-Closed Electronic Valve with low-power DC solenoid can be directly converted to high pressure pneumatic power without electronic amplification.

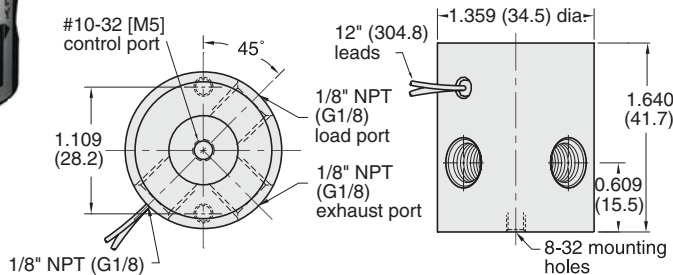

Top View

Side View

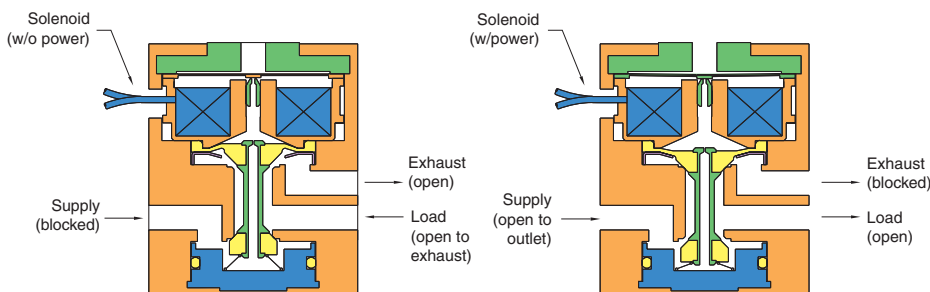

Valve Closed

Valve Open

**Medium:** Air

**Material:** Anodized aluminum body, Buna-N diaphragms

**Input Pressure:** 30 to 100 psig/2 to 7 bar max.

**Air Flow:** 22 scfm @ 100 psig; 530 l/min @ 6 bar

**Bleed:** 0.1 scfm @ 100 psig

**Filtration:** 10 micron

**Frequency Response:** 50 Hz @ 100 psig; 70 Hz @ 30 psig

**Switching Speed:** 10 milliseconds

**Leads:** 28 gauge stranded PVC insulated

**Continuous Overload:** 350% @ 25°C ambient; 250% @ 50°C ambient

**Power Consumption:** less than 0.50 watts at rated voltage  
80 ma. @ 6V  
40 ma. @ 12V  
20 ma. @ 24V

Part No.	Description
<b>2013-6</b>	Valve, 6 Volts DC, 1/8" NPT
<b>2013-12</b>	Valve, 12 Volts DC, 1/8" NPT
<b>2013-24</b>	Valve, 24 Volts DC, 1/8" NPT
<b>2013-6-MG</b>	Valve, 6 Volts DC, G1/8
<b>2013-12-MG</b>	Valve, 12 Volts DC, G1/8
<b>2013-24-MG</b>	Valve, 24 Volts DC, G1/8